

Asphalt Zipper®



**ROADBASE
RECLAIMER**

**AZ-500B
SPECIFICATIONS**

World Leader in Portable Reclaimers / Stabilisers / Utility Trenchers



1.2m Cutting Width Roadbase Reclaimer/Stabiliser



The AZ-500B harnesses the power and productivity of much larger self-propelled stabiliser / reclaimers into a very powerful, versatile and affordable loader attachment. Powered by a John Deere or Cummins (Tier 3) intercooled turbo-diesel engine, the AZ-500B will pulverize up to 300mm in a single pass with productivity up to **450m² / hr.** Heavy patches, full road repairs, base stabilisation, gravel roads and opening utility trenches in asphalt are just a few of its many uses.

CONTACT US FOR DEMONSTRATION AND HIRE DETAILS

www.gradecontrol.com.au

02 43851041

Standard Features



Magnum-duty, case-hardened planetary ensures maximum durability and reliability.



Hydraulic top hatch simplifies bit inspection and replacement. With automatic safety lockout.

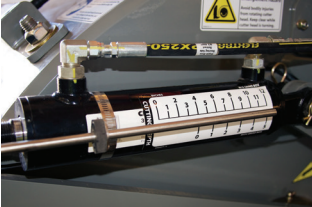

Hydraulic depth adjustment provides convenient, accurate control of cutting depth.

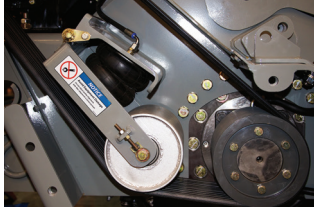

Pressurized belt tensioning conveniently provides consistent belt tension and improved shock handling.

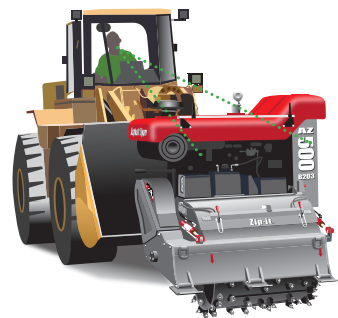

Low-profile design provides superior visibility with all mounting options.

Controls and Monitoring



Side-mounted machine control panel gives groundsman safe and easy control of all machine functions and emergency stop (E-Stop).



Host vehicle control box provides loader operator with a comprehensive engine monitoring computer, tachometer and hard-wired emergency stop (E-Stop).

Wireless remote control gives maximum control, convenience, and safety in operating the Asphalt Zipper®. Regulates engine speed, depth adjustment, and machine stop, plus side shift and tilt if that option has been selected.



4-Function controls engine speed, depth adjustment and machine stop



8-Function also includes side shift and tilt for models with this option.

Cutting Head Options

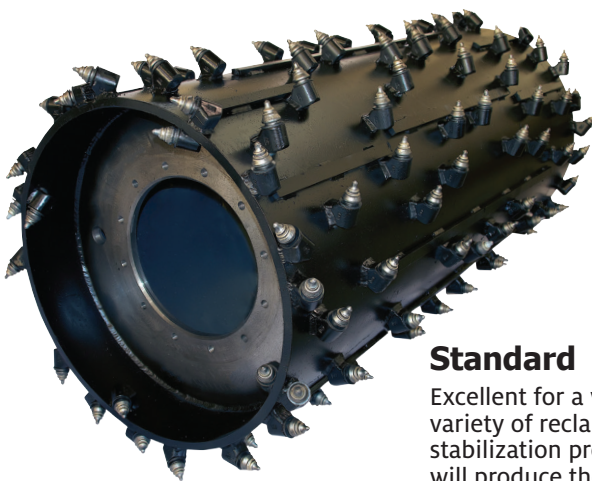

Standard

Excellent for a wide variety of reclamation/stabilization projects and will produce the finest material, particularly in thinner, cracked surfaces.



Outstanding all-around reclamation/stabilization head with increased production and durability, particularly in thicker pavements.

Available widths

48" | 1219 mm

36" | 914 mm

30" | 762 mm

24" | 609 mm

Options

Mounting Options

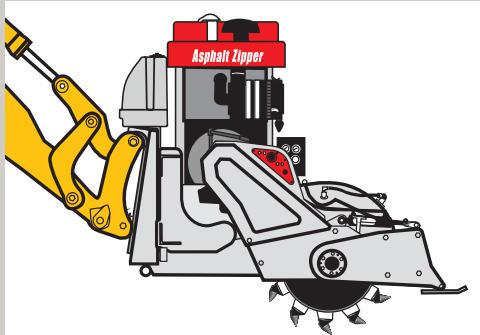

Quick Coupler

Mounts the AZ-500B to your loader's Quick Coupler system.

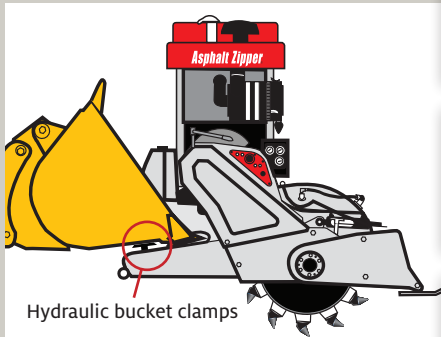

Hydraulic bucket clamps



Versa-Mount™ Universal Coupler

Mounts the AZ-500B to the widest range of loaders, with patented Versa-Mount™ universal bucket mounting system.

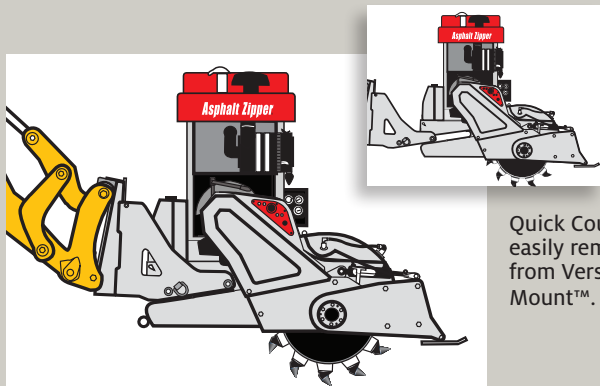

Quick Coupler is easily removed from Versa-Mount™.

Removable Quick Coupler

Mounts the AZ-500B to either the Quick Coupler or, when removed, to the Versa-Mount™ system, providing the flexibility of using either mounting system.

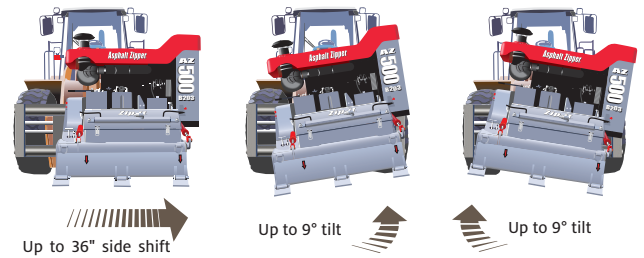

Up to 36" side shift

Up to 9° tilt

Up to 9° tilt

Side shift and tilt capability can be easily added to either Quick Coupler option. Provides up to 36 inches of side shift and up to 9 degrees of tilt. Includes Quick Coupler hooks.



Gator Pro™ enhanced pulverizing containment system improves the unsurpassed pulverizing capability of an Asphalt Zipper® even more in thin, cracked or alligatored asphalt and chipseal, to produce the finest material achievable in these conditions.



Front wheel assist enables the AZ-500B to be operated on smaller host vehicles by offsetting a portion of the machine's weight to a front wheel system. Includes remote-controlled power steering.



Hitch-mount water supply system is available in 150- or 300-gallon sizes.





Dedicated custom trailer provides the easiest way to transport the AZ-500B from site to site behind most work trucks. Includes on-board custom tool box so you have everything you need for operation and routine maintenance in one secure place.



GWYDIR SHIRE NSW
No heavy patch failures in 6 years

Specifications

Turbo-Diesel Engine Options	 Deere 173 hp	 Cummins 203 hp	 HOT-ROD MODEL Cummins 260 hp	Planetary	Magnum-duty Fairfield planetary
Torque	527 ft-lb 715 nm	695 ft-lb 942 nm	730 ft-lb 988 nm	Transport	Tows behind 1-ton pickup on tandem-axle trailer (included)
Cutting Speed*	4000 ft ² /hr 372 m ² /hr	4800 ft ² /hr 446 m ² /hr	6000 ft ² /hr 557 m ² /hr	Mounting	Mounts on most loader buckets
Weight**	8500 lbs 3856 kg	8250 lbs 3742 kg	8650 lbs 3924 kg	Cutting Teeth	Bullet-head, carbide-tipped
Cutting Width	48 in (36", 30" or 24" available) 1219 mm (914, 762 or 609 mm available)			Depth Control	Hydraulic
Cutting Depth	0 to 12 in 0 to 300 mm			Additional Features	<ul style="list-style-type: none"> • Top-opening bit hatch • Pressurized belt tensioning • Hydraulic bucket clamps

* Actual results may vary, depending on asphalt thickness, hardness, temperature, oil content, age, desired grind, etc.

** With standard cutter head installed.

Asphalt Zipper reserves the right to change specifications at any time.

U.S. Patent nos. 7036252, 7066555. Other U.S. and Canadian patents pending.



GRADE
CONTROL

02 43851041
gradecontrol.com.au