



**GRADE**  
CONTROL

**02 43851041**  
[www.gradecontrol.com.au](http://www.gradecontrol.com.au)



**PROFILERS / STABILISERS / BROOMS & ATTACHMENTS**

# PROFILER / STABILISER

Power and efficiency are the hallmark of all Hydropower products and our range of profilers are no exception to this rule – from durable heavy duty Australian design to high quality components.

Designed for skid steers this is a robust attachment that exceeds our renowned **"Quality without compromise"** approach to design and manufacture.

Ideal for skid steer loaders we have a profiler suitable for your application.

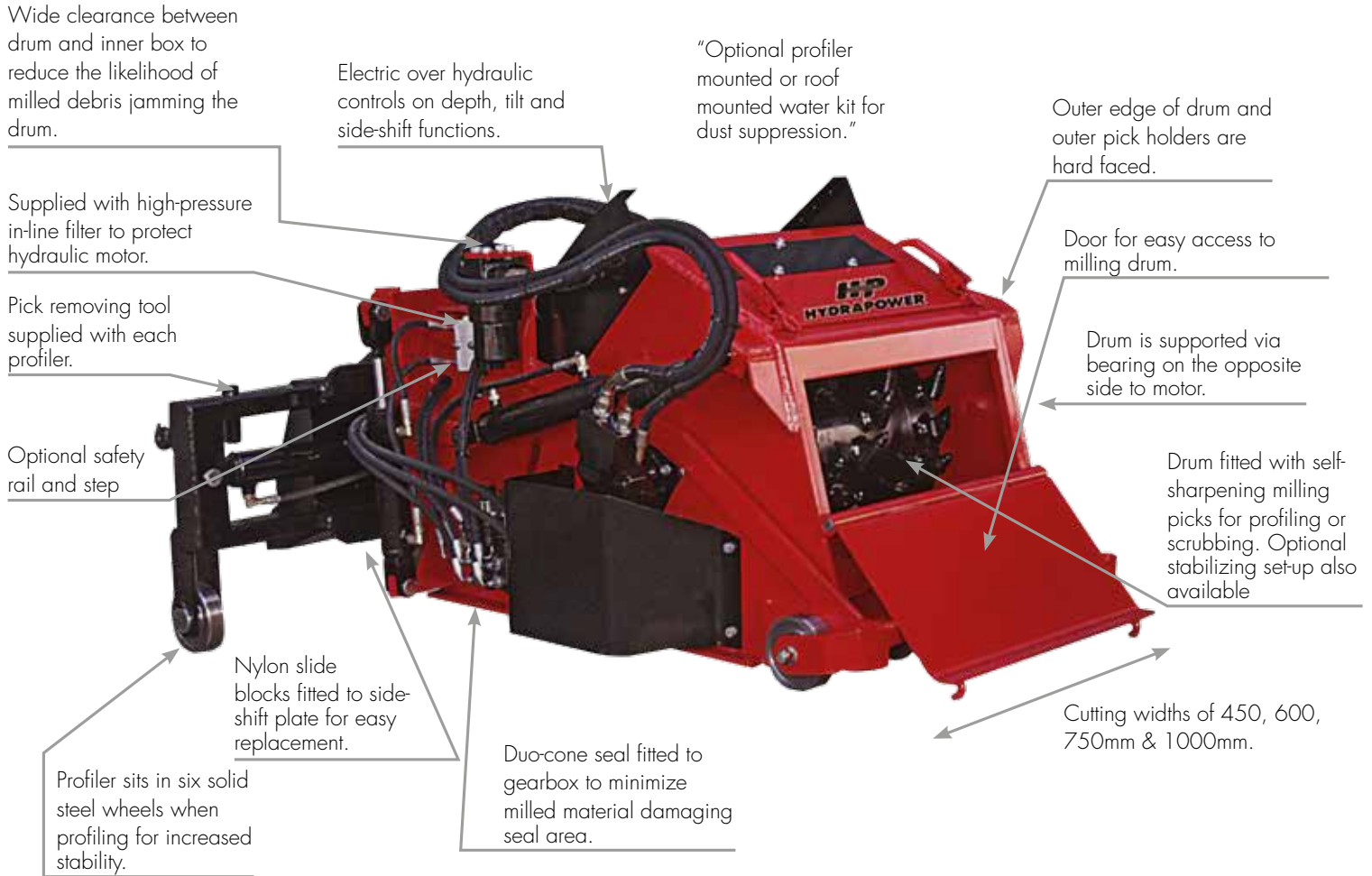

TECHNICAL SPECIFICATIONS	
<b>Host Machine Size</b>	High-Flow Skid Steer (Wheeled or Tracked)
<b>Primary Task</b>	Repairing Road Failures and/or Road Stabilising
<b>Depth Control</b>	Hydraulic - infinitely variable
<b>Drive Mechanism</b>	Hydraulic motor via a planetary gearbox fitted with a duo-cone seal



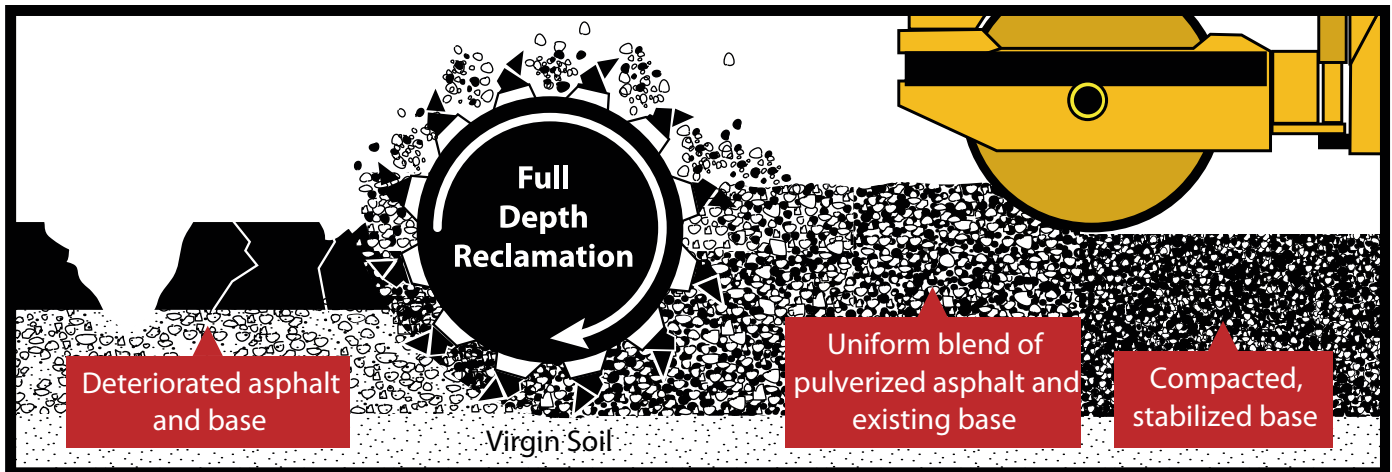

- State Of The Art road stabiliser;
- Runs at 14 metres/minute, at full depth, depending on road condition;
- Engine Type : John Deere / Cummins
- Engine Size : 203 hp
- Working Depth 300mm

# 92TS TRACTOR STABILISER

- Suits minimum 84 KW (115 HP) tractor with creeper gear.
- Stabilises 1800mm wide x 300 mm deep (other widths available).
- Ideal for working on country roads.
- Capable of travelling between jobs at 40 km/h
- Built in, closed loop hydraulic circuit, including oil cooler and comprehensive filtration, with pumps driven off tractor PTO.
- Hydraulically operated height adjustment.
- 120 litre Hydraulic oil tank
- Hydraulically operated rear covers to ensure cutting area covered at all cutting depths.



# FLAIL MOWER & MULCHER



## **MULCHER/FLAIL MOWER**

Suit Skid Steer

Hydraulic forestry flail/mulcher for skid steer loaders to mulch any vegetable residue, branches and standing plants. Ideal for clearing derelict areas e.g. under powerlines, creation of fire breaks etc...



From 1600mm wide

## **FLAIL MOWER**

Suit Excavator

900mm wide  
Cutting capacity of up to 100mm (4")  
Hydraulic flow rate 20-75 lpm @ 3000 psi



## RBH Bucket Broom

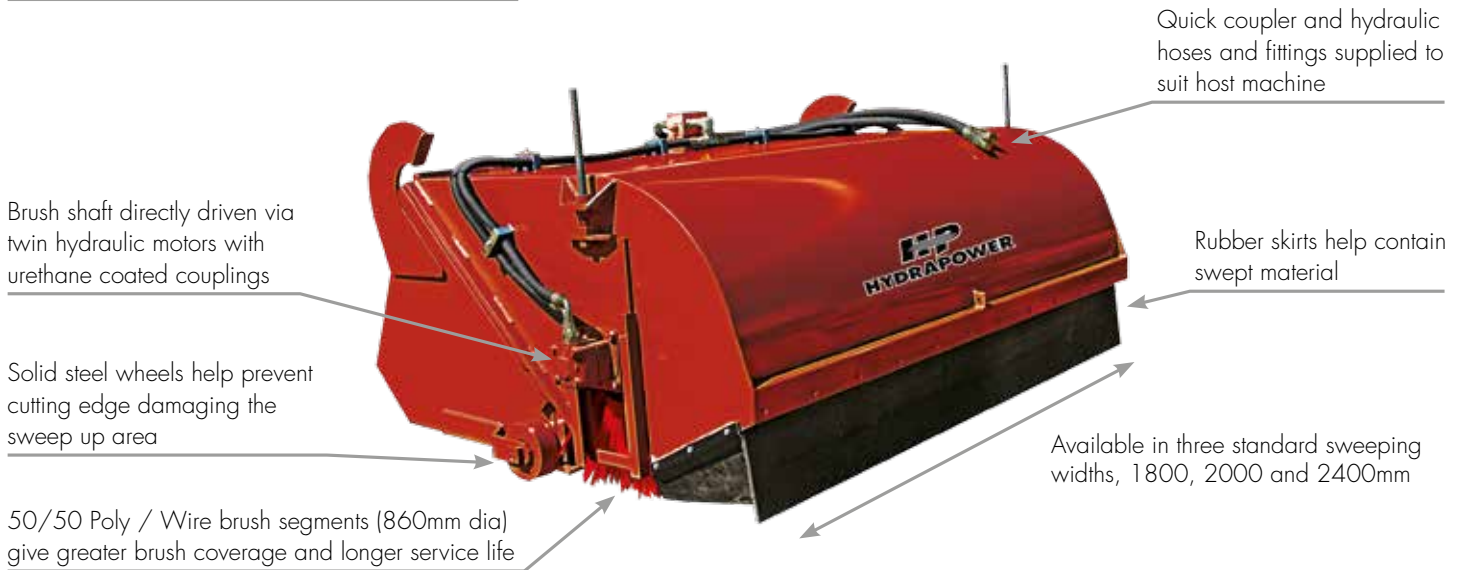

Available in four standard sweeping widths, 1600, 1700, 1800 and 2000mm

## RW Bucket Broom



## FB Bucket Broom



# ANGLE SWEEPERS

## RS Angle Sweeper



## AS Angle Sweeper

Available in three standard sweeping widths, 1800, 200 and 2200 mm.

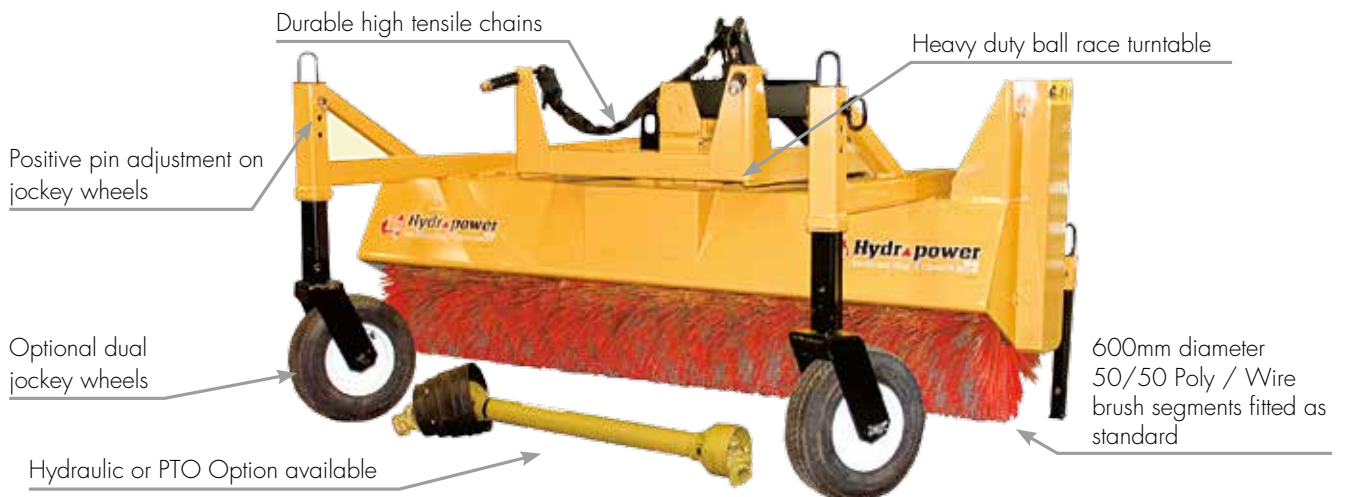

## LAS Angle Sweeper



## Premium Heavy Duty Model

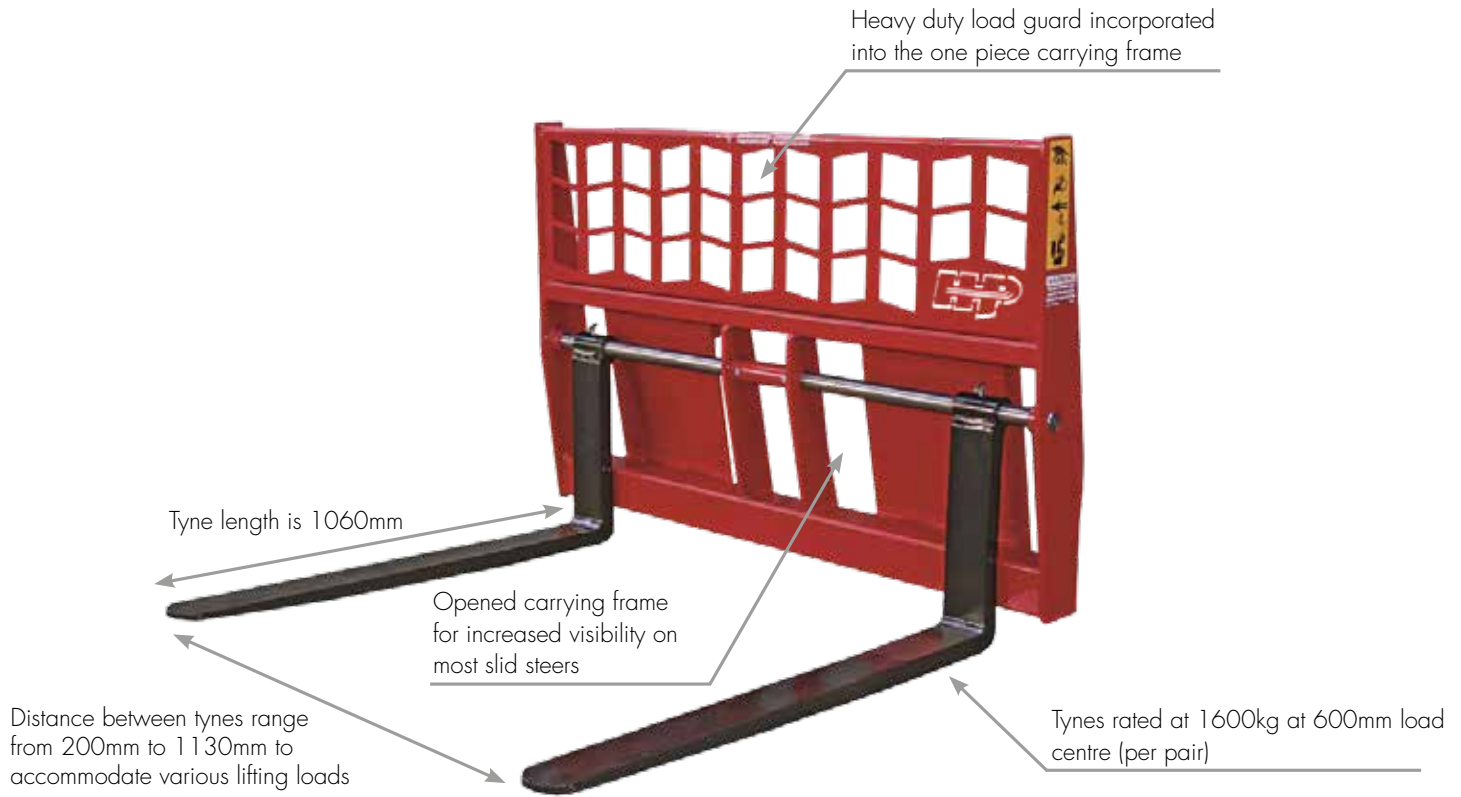

## Imported Utility Medium Duty Model







- Loading
- Mixing
- Unloading

Especially recommended for construction and maintenance of concrete paving, sewers and culverts, pavements, kerbs and gutters.

Has hitch to suit Skid Steer Loader – Excavator Hitch also available

Supply includes loading pipe – 1500mm x 200mm which allows discharge when necessary

Example of productivity  
Model BM250 : 1m<sup>3</sup> - 20 minutes

\*Optional side chute



# Utility

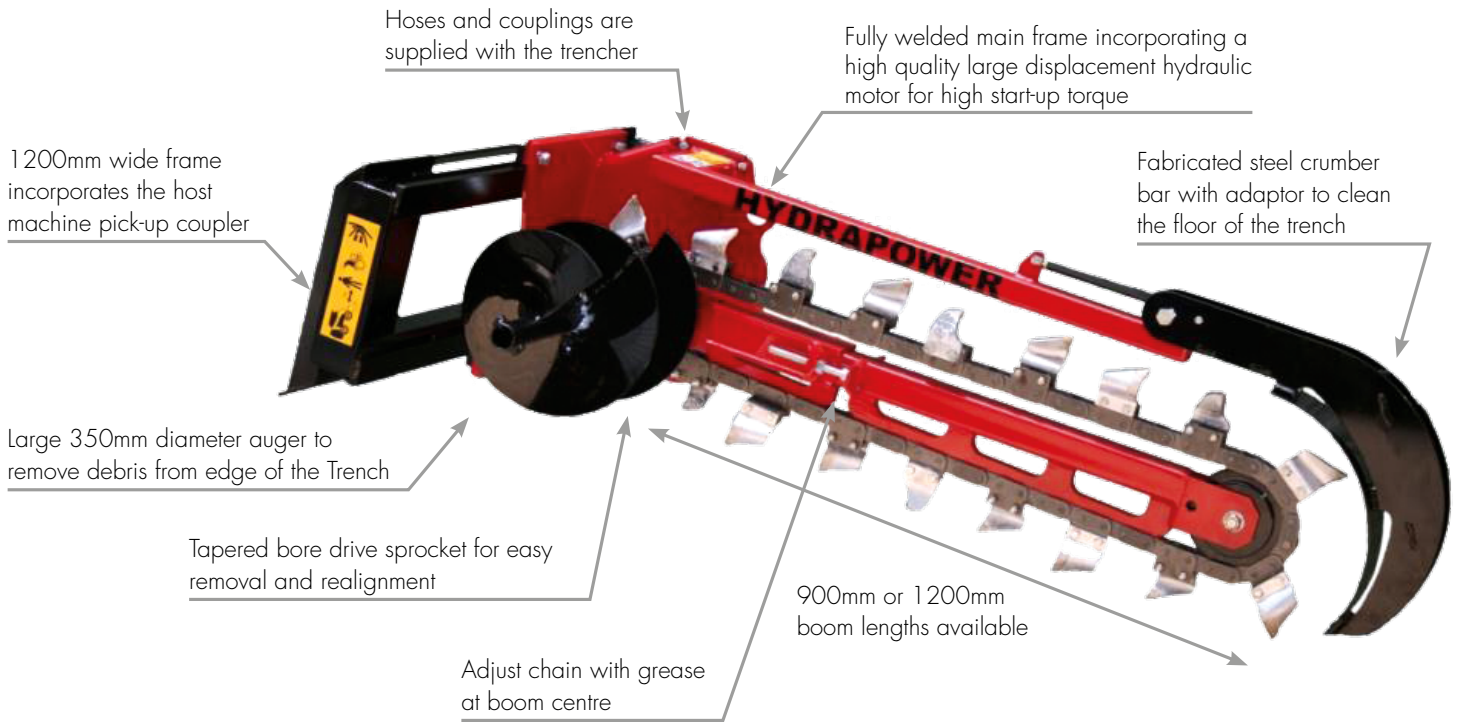

# HT2

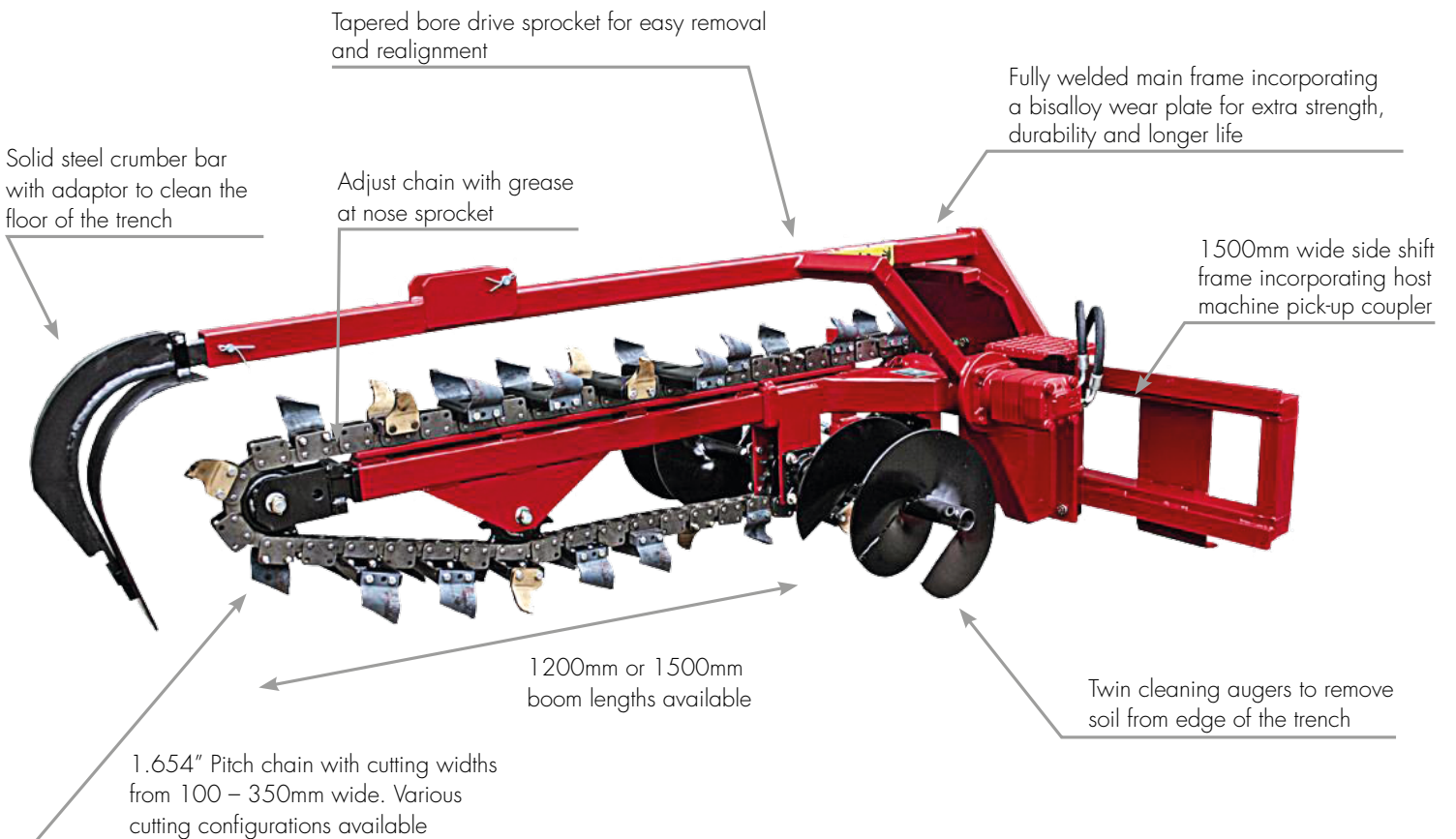

## HT3

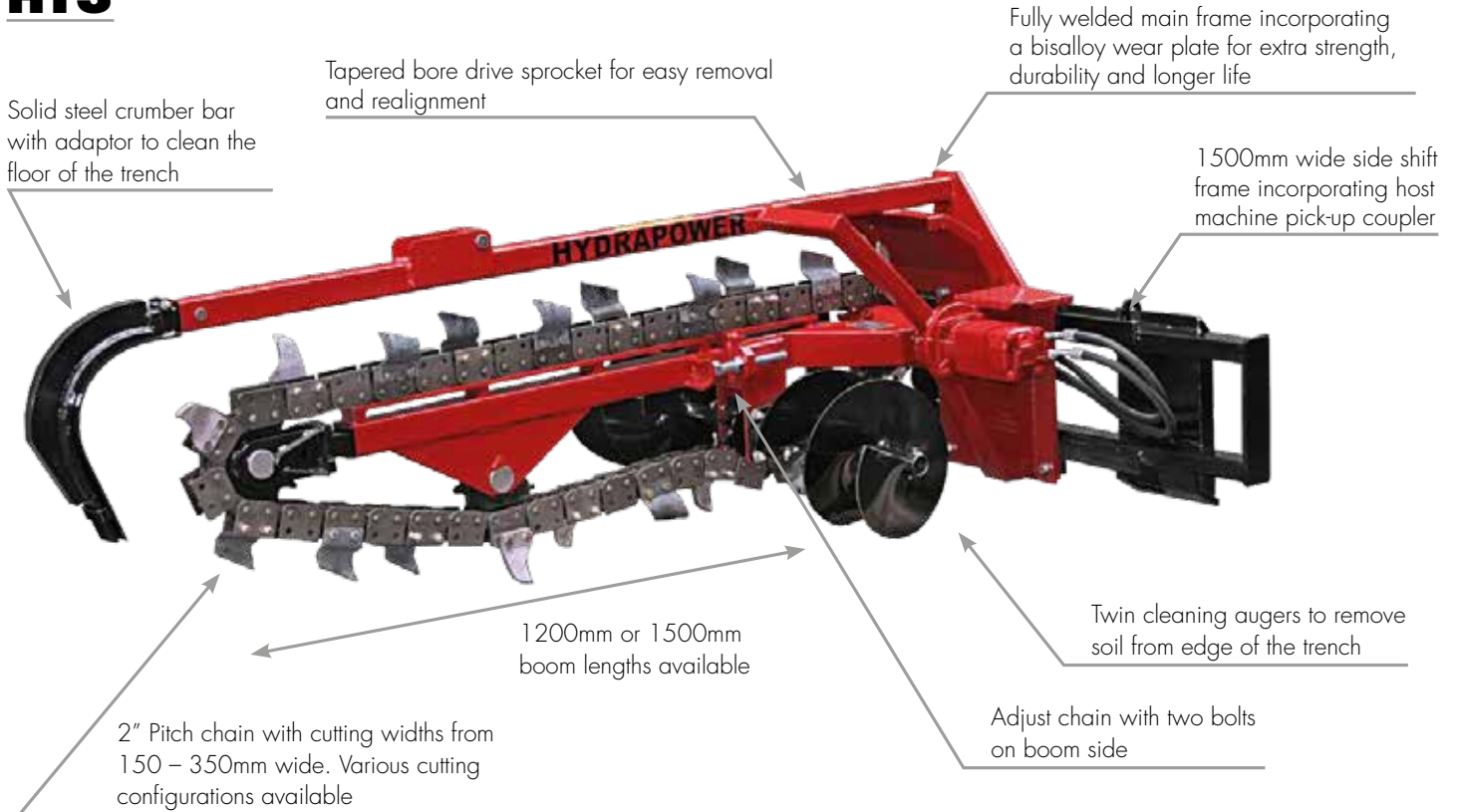

**ONLY THE HT3 HAS 360 GRADE SPROCKETS**

## Debris Scraper

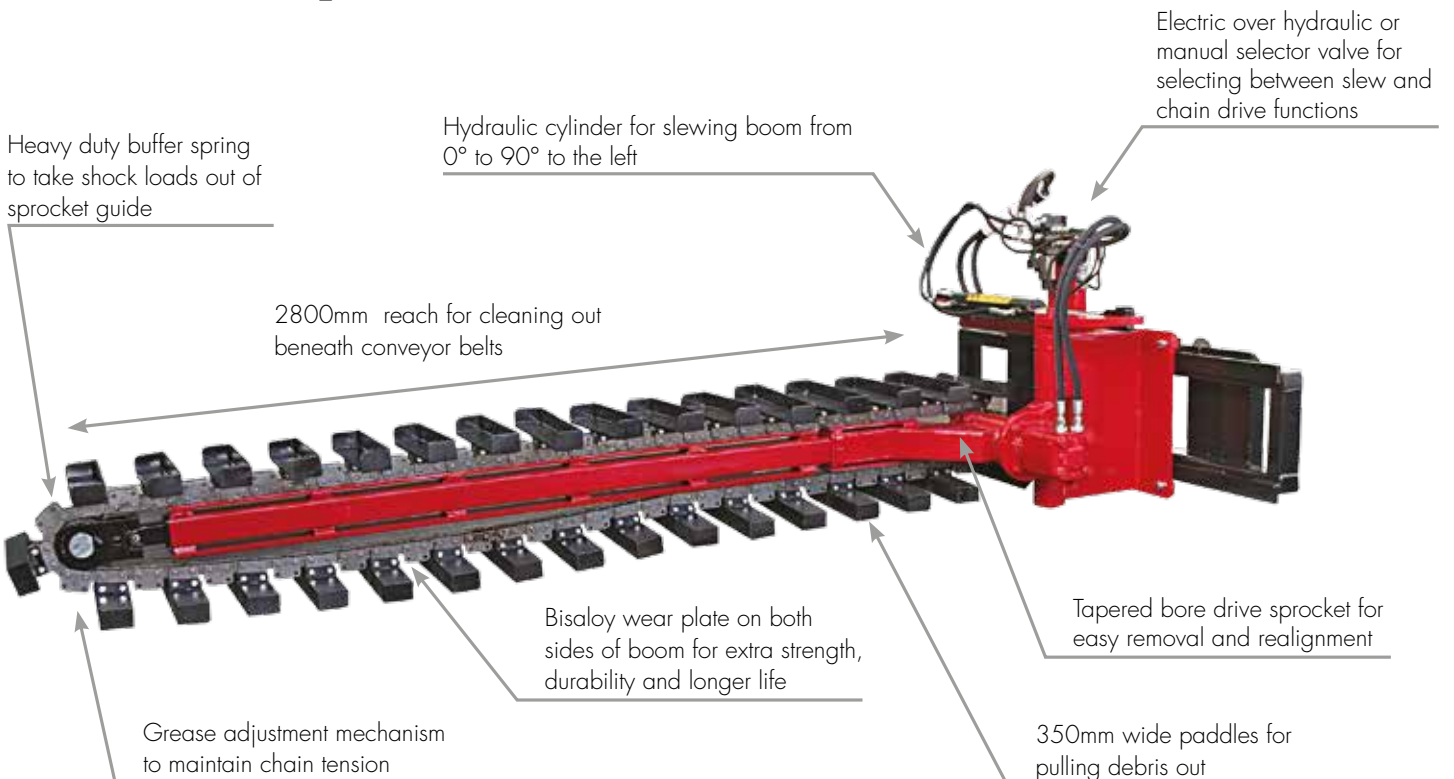

## Double Head Slasher

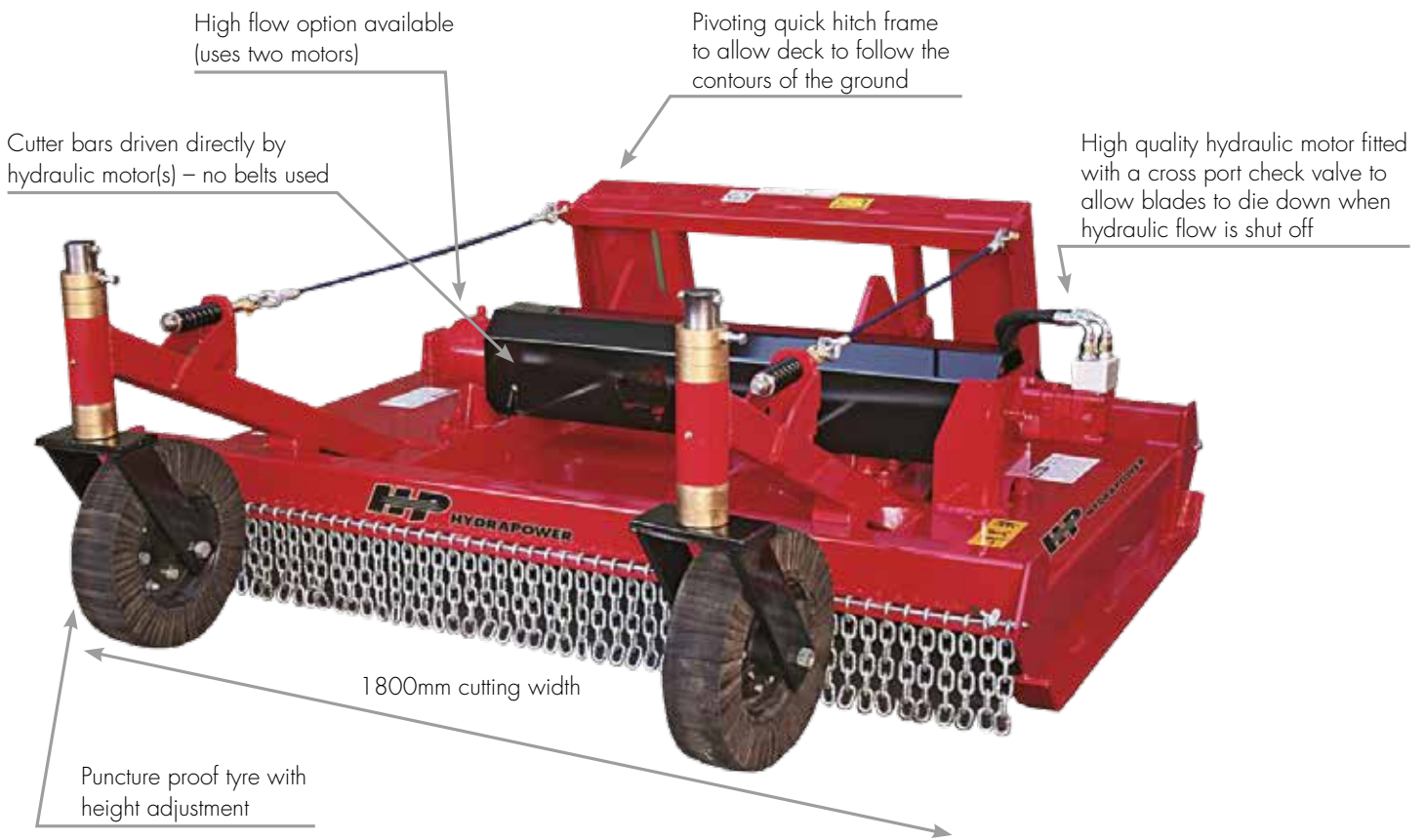

## Grader Attachment



## **Brush Rake**

- Universal back plate
- No moving parts and long tynes, for reduced wear
- From 1600mm long



## **Tree Spade**

- Closed back to allow material to be carried in bucket
- Spade with 43" (1090mm) width, 44" (1120mm) depth and 26" (660mm) height



## **Skeleton Bucket**

- Tynes spaced to pick up only larger rocks and no dirt
- From 1600mm long





## **Backhoe**

- Boom reach  $\pm$  2m
- Dig depth  $\pm$  2m



## **Hitch Plate**

- Universal back plate
- Rated weight of implement to be attached: 3000lbs (1360Kg)
- Weight of plate: 128lbs (58Kg)



## **Hedge Trimer for Excavator**

- 5ft (1500mm) sickle
- Hydraulic flow requirements: 10-20gpm (38-76 lpm)
- Weight of unit: 125lbs (57Kg)

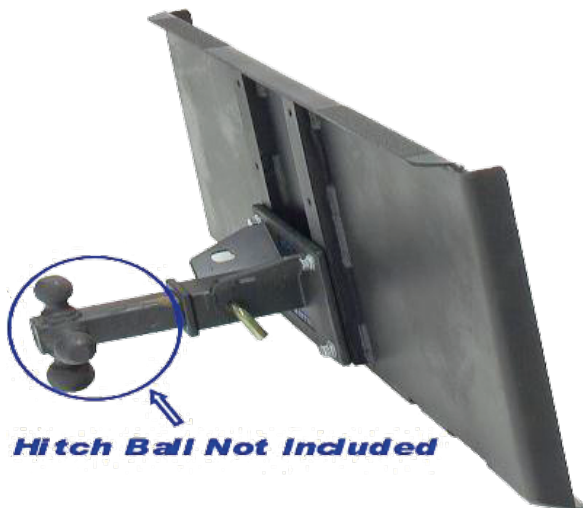

## **Tow Bar Hitch**

- Universal back plate

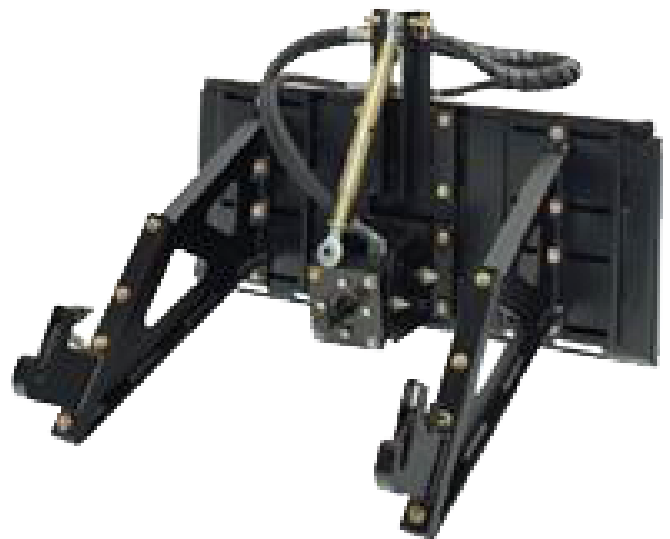

## **3 Point Powered Adaptor**

- Can be fitted with 80, 125, 160 or 200cc motor

## **High Impact Post Driver**

- Gas charged
- Optional tilt tach available
- Width 45" (1140mm), height 65" (1350mm)
- Driving force 55lbs (250Kg) direct impact
- Driver head 8" (200mm)
- Weight 1230lbs (558Kg)



## **Forksweep**

Suit fork lift host machine (optional gutter brush)

- 1250mm wide
- 660mm diameter brush
- Optional side broom(s) / gutter brushes

# **WE CARRY A WIDE RANGE OF SPARE PARTS FOR OUR ATTACHMENTS, INCLUDING....**

## **BROOMS**

**BRUSH SEGMENTS & SPACERS**

**BROOM SHAFTS**

**CUTTING EDGES**

**HYDRAULIC MOTORS**

**DRIVE COUPLINGS**

**BEARINGS**

**STEEL WHEEL ASSEMBLIES (WHERE APPROPRIATE TO MODEL)**

## **PROFILERS**

**HYDRAULIC MOTORS**

**FILTER ELEMENTS**

**PICKS**

**PICK HOLDERS**

**STEEL WHEEL ASSEMBLIES**

## **TRENCHER / SCRAPERS**

**SPROCKETS AND SPROCKET ASSEMBLIES**

**BEARINGS**

**BUFFER SPRINGS**

**CHAINS**

**TEETH**

**JOINER LINKS**

## **SLASHERS**

**HYDRAULIC MOTORS**

**GEARBOXES**

**STUMP JUMP CUTTER BARS**

**BLADES**

**JOCKEY WHEELS**

**AND MANY MORE.....**

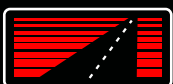

**GRADE  
CONTROL**

**02 43851041**  
[www.gradecontrol.com.au](http://www.gradecontrol.com.au)